



Culvert Maintenance

---

## CULVERT MAINTENANCE



Technical Standards Branch  
Class B Bridge Inspection Course



Culvert Maintenance

---

## Culvert Maintenance

- Similar to bridges
  - approach road
  - channel
- Structurally different
  - upstream end
  - downstream end
  - barrel



Technical Standards Branch  
Class B Bridge Inspection Course



Culvert Maintenance

---

## Maintenance Recommendations

Maintenance Recommendations				
Inspector Recommendations	Year	Inspector Comments	Department Comments	Target Year, Est. Cost, CUL #
APPROPRIATE REPAIRS				
PLACE ADDITIONAL REPAIR				
REMOVE WEAR FACED SURFING				
INSTALL CONCRETE/STEEL LINING				
INSTALL BRUSHES				
INSTALL CONCRETE COLLAR/CUTOFF				
REPAIR DAMAGE				
OTHER ACTION				
OTHER ACTION				
OTHER ACTION				
OTHER ACTION				
OTHER ACTION				

Lead Inspected Condition Rating (%)	Lead Reliability Rating (%)	Submittal Requirement Year	Maintenance Required (CUL)

Maintenance Recommended By: \_\_\_\_\_ Date: \_\_\_\_\_ Estimated Total: \_\_\_\_\_

Proposed Long Term Strategy: \_\_\_\_\_

On 3-Year Program (Y/N): \_\_\_\_\_

Proposed Action: \_\_\_\_\_

Previous Inspector's Name: \_\_\_\_\_ Date Inspected: \_\_\_\_\_

Next Inspector's Name: \_\_\_\_\_ Date Inspected: \_\_\_\_\_

Inspection Circle (initials): \_\_\_\_\_

Comments: \_\_\_\_\_

- CULM and CULE form recommendations are identical



Technical Standards Branch  
Class B Bridge Inspection Course



Culvert Maintenance

---

## Approach Road Maintenance

- Embankment
  - slides, slumps, etc.
    - repair by removing failed material & replacement with competent, compacted material
  - remaining items same as for bridges



Technical Standards Branch  
Class B Bridge Inspection Course



Culvert Maintenance

---

## Upstream / Downstream End Maintenance

- Upstream & Downstream ends have the same inspection items
- Head Wall
  - usually a low maintenance item
  - broken, spalled concrete
    - patch
  - scaled concrete
    - repair & seal (when salt applied to roads)

---



Technical Standards Branch  
Class B Bridge Inspection Course



BIM  
Bridge Inspection and Maintenance

4

Culvert Maintenance

---

## Upstream / Downstream End Maintenance (Cont'd)

- Collar / Concrete Slope Protection
  - scoured / eroded
    - compacted fill and rock riprap
  - settled & broken
    - replace with fill and riprap

---



Technical Standards Branch  
Class B Bridge Inspection Course



BIM  
Bridge Inspection and Maintenance

5

Culvert Maintenance

---

### Adding end treatment to existing culvert.



---



Technical Standards Branch  
Class B Bridge Inspection Course



BIM  
Bridge Inspection and Maintenance

6

Culvert Maintenance

---

## Upstream / Downstream End Maintenance (Cont'd)

- Wingwalls
  - deteriorated concrete
    - chip out and replace
  - separated from barrel
    - fill gap with flexible material
  - pushing inwards
    - strut between

---



Technical Standards Branch  
Class B Bridge Inspection Course



BIM  
Bridge Inspection and Maintenance

7

Culvert Maintenance

---

Damaged floor at outlet transition.



 Technical Standards Branch  
Class B Bridge Inspection Course 



8

Culvert Maintenance

---

Horizontal Strut





 Technical Standards Branch  
Class B Bridge Inspection Course 

Culvert Maintenance

---

**Upstream / Downstream End  
Maintenance (Cont'd)**

- Cutoff Wall
  - usually buried if present
  - if not present and a problem with piping
    - Install cut off wall

 Technical Standards Branch  
Class B Bridge Inspection Course 



10

Culvert Maintenance

---

Adding cut-off wall to existing culvert.



 Technical Standards Branch  
Class B Bridge Inspection Course 

11

Culvert Maintenance

---

Wash out due to piping  
(Brewster Creek Sunchild Road)



12



Technical Standards Branch  
Class B Bridge Inspection Course



Culvert Maintenance

---

**Upstream / Downstream End Maintenance (Cont'd)**

- Bevel End
  - excessive heaving
    - remove and reset with end treatment
    - replace with new end treatment
  - folding in
    - add collar
  - current end treatment requirements are:
    - 1.5 to 3.0m special conditions
    - 3.0 to 4.5m upstream end only
    - >4.5m both ends

13



Technical Standards Branch  
Class B Bridge Inspection Course



Culvert Maintenance

---

Heaved inlet on CSP culvert.



14



Technical Standards Branch  
Class B Bridge Inspection Course



Culvert Maintenance

---

**Upstream / Downstream End Maintenance (Cont'd)**

- Scour Protection
  - Erosion / scour
    - add suitable size rock riprap with filter cloth to apron and/or around collar or bevel
- Scour / Erosion
  - scour / erosion
    - add rock riprap with filter cloth to suit velocities anticipated

15



Technical Standards Branch  
Class B Bridge Inspection Course



Culvert Maintenance

High velocity at outlet during high water  
(Big or Bald Mountain Hwy 40)



16

Alberta Transportation

Technical Standards Branch  
Class B Bridge Inspection Course



Culvert Maintenance

Extreme turbulence at outlet.



17

Alberta Transportation

Technical Standards Branch  
Class B Bridge Inspection Course



Culvert Maintenance

Downstream bed erosion and bank erosion at bend.



18

Alberta Transportation

Technical Standards Branch  
Class B Bridge Inspection Course



Culvert Maintenance

**Downstream Apron Repair**

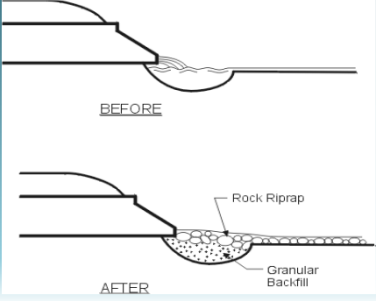

19

Alberta Transportation

Technical Standards Branch  
Class B Bridge Inspection Course



Culvert Maintenance



---

## Upstream / Downstream End Maintenance (Cont'd)

- Rock Riprap Material Size versus Stream Velocity

Riprap Class	Allowable Velocity
Class 1m	- 2.0 m / sec
Class 1	- 3.0 m / sec
Class 2	- 4.0 m / sec
Class 3	- 4.7 m / sec

---

Technical Standards Branch  
Class B Bridge Inspection Course

20



Culvert Maintenance

---

## Upstream / Downstream End Maintenance (Cont'd)

- Degradation
  - restore stream bed elevation
  - add material
- Aggradation
  - restore stream bed elevation
  - remove material

---



Technical Standards Branch  
Class B Bridge Inspection Course

21



Culvert Maintenance

---

### Stream degradation and scour hole.



---



Technical Standards Branch  
Class B Bridge Inspection Course

22



Culvert Maintenance

---

### Hanging outlet due to degradation and scour.





---

Technical Standards Branch  
Class B Bridge Inspection Course

23

Culvert Maintenance

Typical scour and degradation at outlet



24

Alberta  
Transportation

Technical Standards Branch  
Class B Bridge Inspection Course



Culvert Maintenance

New rip rap added to bevel and apron



Alberta  
Transportation

Technical Standards Branch  
Class B Bridge Inspection Course



Culvert Maintenance

Streambed aggradation (Cougar Creek Canmore).



26

Alberta  
Transportation

Technical Standards Branch  
Class B Bridge Inspection Course



Culvert Maintenance

Restored inlet.



27

Alberta  
Transportation

Technical Standards Branch  
Class B Bridge Inspection Course



Culvert Maintenance

---

## Barrel Maintenance

- Roof
  - Sagging 15% or more
  - Reverse curvature
    - add struts (or install liner if still adequate capacity).

---



28

Technical Standards Branch  
Class B Bridge Inspection Course



Culvert Maintenance

---

## Reverse curvature in roof



---



29

Technical Standards Branch  
Class B Bridge Inspection Course



Culvert Maintenance

---

## Barrel Maintenance

- Sidewall
  - deflecting
    - add struts (or install liner if adequate capacity)
  - corroded
    - Install liner
    - cathodic protection (not as common as previously)

---



30

Technical Standards Branch  
Class B Bridge Inspection Course



Culvert Maintenance

---

## Failed SPCSP culvert (inadequate backfill).



---



31

Technical Standards Branch  
Class B Bridge Inspection Course





Culvert Maintenance

Soil side corrosion, perforated side wall.



32

Alberta Transportation

Technical Standards Branch  
Class B Bridge Inspection Course



Culvert Maintenance

### Barrel Maintenance

- Floor
  - bulging
    - Place U/S cut-off wall if piping
    - add struts or install liner
  - corroding
    - cast concrete floor
    - cathodic protection

33

Alberta Transportation

Technical Standards Branch  
Class B Bridge Inspection Course



Culvert Maintenance

### Floor perforations



Alberta Transportation

Technical Standards Branch  
Class B Bridge Inspection Course



Culvert Maintenance

Arch shaped CSP with heaved floor and deflecting roof.



35

Alberta Transportation

Technical Standards Branch  
Class B Bridge Inspection Course



Culvert Maintenance

Strutted barrel



36

Alberta Transportation

Technical Standards Branch  
Class B Bridge Inspection Course



Culvert Maintenance

Concrete arch culvert with curved wingwalls in Feb. (Weed Creek)



37

Alberta Transportation

Technical Standards Branch  
Class B Bridge Inspection Course



Culvert Maintenance

Arch culvert after high water in July.



38

Alberta Transportation

Technical Standards Branch  
Class B Bridge Inspection Course



Culvert Maintenance

Culvert outlet after high water.



39

Alberta Transportation

Technical Standards Branch  
Class B Bridge Inspection Course



Culvert Maintenance

Inlet of new culvert, following winter.



40

Alberta  
Transportation

Technical Standards Branch  
Class B Bridge Inspection Course



Culvert Maintenance

Hwy. 40 Lineham Creek – Washout of  
4.3m SPE – 2013 Flood Event - Outlet



Alberta  
Transportation

Technical Standards Branch  
Class B Bridge Inspection Course



Culvert Maintenance

Hwy. 40 Lineham Creek – Washout of  
4.3m SPE – 2013 Flood Event - Inlet



Alberta  
Transportation

Technical Standards Branch  
Class B Bridge Inspection Course



Culvert Maintenance

Hwy. 40 Lineham Creek – Washout of  
4.3m SPE – 2013 Flood Event



Alberta  
Transportation

Technical Standards Branch  
Class B Bridge Inspection Course



Culvert Maintenance

## Hwy. 40 Lineham Creek – Replacement with 8-14-8M SLW girders in 2015



Alberta Transportation
Technical Standards Branch  
Class B Bridge Inspection Course

Culvert Maintenance

## Timber Strutting of Metal Culverts

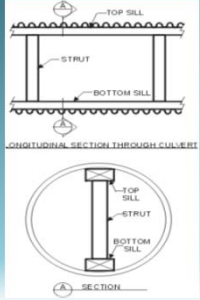

45 Alberta Transportation
Technical Standards Branch  
Class B Bridge Inspection Course

Culvert Maintenance

## Strut detail (Crowfoot Creek Hwy 1).

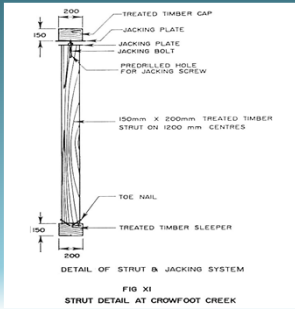



FIG XI  
STRUT DETAIL AT CROWFOOT CREEK

46 Alberta Transportation
Technical Standards Branch  
Class B Bridge Inspection Course

Culvert Maintenance

## Strutting arrangement for horizontal ellipse.

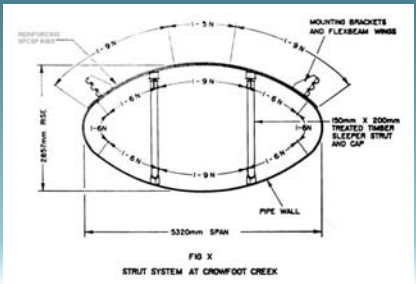



FIG X  
STRUT SYSTEM AT CROWFOOT CREEK

47 Alberta Transportation
Technical Standards Branch  
Class B Bridge Inspection Course

Culvert Maintenance

**Installing adjustable struts.**



48

Alberta Transportation

Technical Standards Branch  
Class B Bridge Inspection Course

BIM  
Bridge Inspection and Maintenance

Culvert Maintenance

**Completed installation.**



49

Alberta Transportation

Technical Standards Branch  
Class B Bridge Inspection Course

BIM  
Bridge Inspection and Maintenance

Culvert Maintenance

**Culvert Liners**

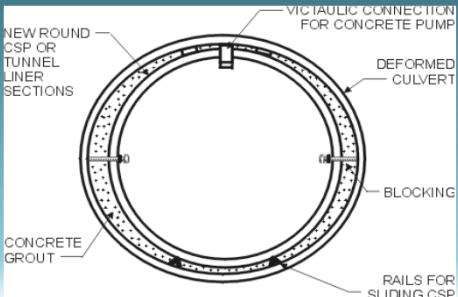

NEW ROUND CSP OR TUNNEL LINER SECTIONS

VICTAULIC CONNECTION FOR CONCRETE PUMP

DEFORMED CULVERT

BLOCKING

RAILS FOR SLIDING CSP

CONCRETE GROUT

50

Alberta Transportation

Technical Standards Branch  
Class B Bridge Inspection Course

BIM  
Bridge Inspection and Maintenance

Culvert Maintenance

**Installing a CSP liner.**



51

Alberta Transportation

Technical Standards Branch  
Class B Bridge Inspection Course

BIM  
Bridge Inspection and Maintenance

Culvert Maintenance

---

SPCSP liner is assembled outside and then pulled into existing culvert.



52

Alberta Transportation

Technical Standards Branch  
Class B Bridge Inspection Course



Bridge Inspection and Maintenance

Culvert Maintenance

---

For larger culverts, tunnel liner plates are used.



53

Alberta Transportation

Technical Standards Branch  
Class B Bridge Inspection Course



Bridge Inspection and Maintenance

Culvert Maintenance

---

Liner installed ready for grouting.



54

Alberta Transportation

Technical Standards Branch  
Class B Bridge Inspection Course



Bridge Inspection and Maintenance

Culvert Maintenance

---

### Barrel Maintenance

- Circumferential Seams
  - separated
    - inject concrete or grout
    - Install inside coupler plates
- Longitudinal Seams
  - cracked
    - monitor
    - shotcrete reinforcement
    - cast 1/2 arc concrete
    - install liner

55

Alberta Transportation

Technical Standards Branch  
Class B Bridge Inspection Course



Bridge Inspection and Maintenance

Culvert Maintenance

Properly lapped seam.



56

Alberta  
Transportation

Technical Standards Branch  
Class B Bridge Inspection Course



Bridge Inspection and Maintenance

Culvert Maintenance

Incorrectly lapped seam with poor nesting



57

Alberta  
Transportation

Technical Standards Branch  
Class B Bridge Inspection Course



Bridge Inspection and Maintenance

Culvert Maintenance

Incorrectly lapped seam with cracks



58

Alberta  
Transportation

Technical Standards Branch  
Class B Bridge Inspection Course



Bridge Inspection and Maintenance

Culvert Maintenance

Longitudinal Seam Reinforcing

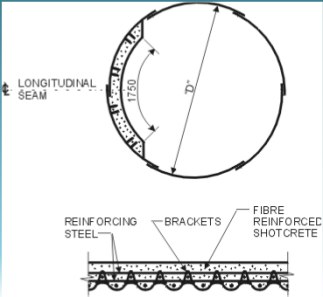

59

Alberta  
Transportation

Technical Standards Branch  
Class B Bridge Inspection Course



Bridge Inspection and Maintenance

Culvert Maintenance

Shotcrete repairs of cracked seams during winter.



Technical Standards Branch  
Class B Bridge Inspection Course



60

Culvert Maintenance

Reinforcing and shear connectors fastened to culvert.



Technical Standards Branch  
Class B Bridge Inspection Course



61

Culvert Maintenance

Shear connector detail.

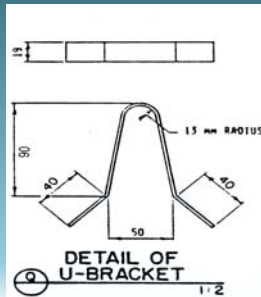

Technical Standards Branch  
Class B Bridge Inspection Course



62

Culvert Maintenance

Shear connectors and rebar in place over cracked seam.



Technical Standards Branch  
Class B Bridge Inspection Course





63



Culvert Maintenance

Shot blaster and heater for inside the culvert.





64  Technical Standards Branch  
Class B Bridge Inspection Course 

Culvert Maintenance

Heater inside culvert. Must be maintained at +5° C.



65  Technical Standards Branch  
Class B Bridge Inspection Course 

Culvert Maintenance

Applying the shotcrete.



66  Technical Standards Branch  
Class B Bridge Inspection Course 

Culvert Maintenance

Completed shotcrete reinforcing beams.



67  Technical Standards Branch  
Class B Bridge Inspection Course 

Culvert Maintenance

**Bottom reinforcement for arch shaped culvert.  
(Nose Creek Hwy 2)**

FIG. XII

Technical Standards Branch  
Class B Bridge Inspection Course

Bridge Inspection and Maintenance

68

Culvert Maintenance

Reinforcing installed for arch culvert reinforcement.

Technical Standards Branch  
Class B Bridge Inspection Course

Bridge Inspection and Maintenance

69

Culvert Maintenance

Floor cast inside arch culvert.

Technical Standards Branch  
Class B Bridge Inspection Course

Bridge Inspection and Maintenance

70

Culvert Maintenance

**Barrel Maintenance**

- Coating
  - Corrosion
    - Soil side corrosion
    - Liner
    - Cathodic protection (not as common as previously)
  - Water side corrosion
    - Concrete floor
    - Liner

Technical Standards Branch  
Class B Bridge Inspection Course

Bridge Inspection and Maintenance

71

Culvert Maintenance

### Galvanic Corrosion

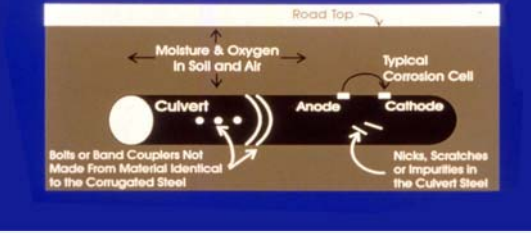

The diagram shows a cross-section of a road and a culvert. At the top is the 'Road Top'. Below it, 'Moisture & Oxygen In Soil and Air' is indicated. A 'Typical Corrosion Cell' is shown with an 'Anode' and a 'Cathode'. The 'Culvert' is shown as a cylinder. Text notes: 'Bolts or Band Couplers Not Made From Material Identical to the Corrugated Steel' and 'Nicks, Scratches or Impurities in the Culvert Steel'.



Technical Standards Branch  
Class B Bridge Inspection Course



72

Culvert Maintenance

### Passive Cathodic Protection System

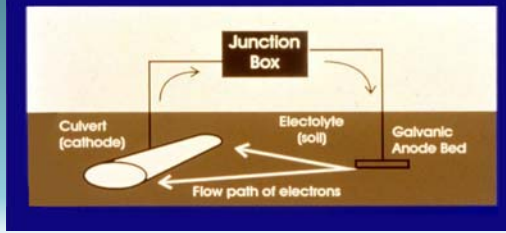

The diagram shows a 'Culvert (cathode)' connected to a 'Galvanic Anode Bed' via a 'Junction Box'. The 'Electrolyte (soil)' is between them. An arrow indicates the 'Flow path of electrons' from the anode bed to the culvert.



Technical Standards Branch  
Class B Bridge Inspection Course



73

Culvert Maintenance

### Culvert Cathodic Protection

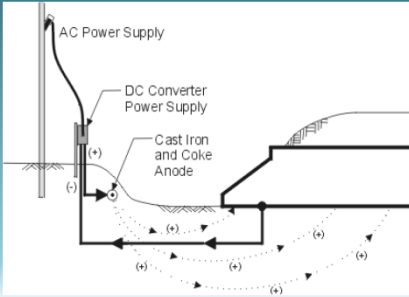

The diagram shows an 'AC Power Supply' connected to a 'DC Converter Power Supply'. This is connected to a 'Cast Iron and Coke Anode' which is buried in the soil. The 'Culvert' is shown as a cylinder. Arrows indicate the flow of current from the anode to the culvert.



Technical Standards Branch  
Class B Bridge Inspection Course



74

Culvert Maintenance

### DC power supply (AC to DC converter).

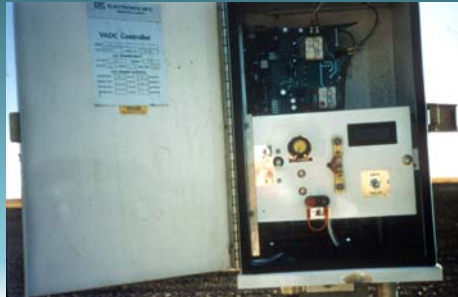

A photograph of a white metal cabinet containing a 'WDC Controller' and other electrical components, which serves as the DC power supply for the cathodic protection system.



Technical Standards Branch  
Class B Bridge Inspection Course



75

Culvert Maintenance

---

**Cast iron and carbon anode.**



76



Technical Standards Branch  
Class B Bridge Inspection Course



Culvert Maintenance

---

**Cross-section of anode.**



77



Technical Standards Branch  
Class B Bridge Inspection Course



Culvert Maintenance

---

**Barrel Maintenance (Cont'd)**

- Fish Passage Adequacy
  - add baffles
    - cast concrete
    - rocks
    - weir type
  - repair / build downstream apron
- Waterway Adequacy
  - install additional culvert (jacking)
  - remove drift or silt
  - install stream lining

78



Technical Standards Branch  
Class B Bridge Inspection Course



Culvert Maintenance

---

**Channel Maintenance**

- Similar to bridges - Degrading (scour), Aggrading
- Drift more of a concern
- Beavers are common
- High velocities at outlet

79



Technical Standards Branch  
Class B Bridge Inspection Course



Culvert Maintenance

Drift collected at inlet (Whitecourt Creek).



80

Alberta Transportation

Technical Standards Branch  
Class B Bridge Inspection Course



Culvert Maintenance

Drift in strutted barrel



Alberta Transportation

Technical Standards Branch  
Class B Bridge Inspection Course



Culvert Maintenance

Questions???

Alberta Transportation

Technical Standards Branch  
Class B Bridge Inspection Course

